

"Y" TYPE CYLINDER CONTROL VALVES

Y型氣缸式控制閥

Y-CCV



適合流體：水、空氣、蒸氣、油
 SUITABLE FLUIDS : WATER, AIR, STEAM, OIL
 工作壓力：0~20 KG/CM²
 WORKING PRESSURE
 工作溫度：0~20 KG/CM² : 0°C~180°C
 WORKING TEMP

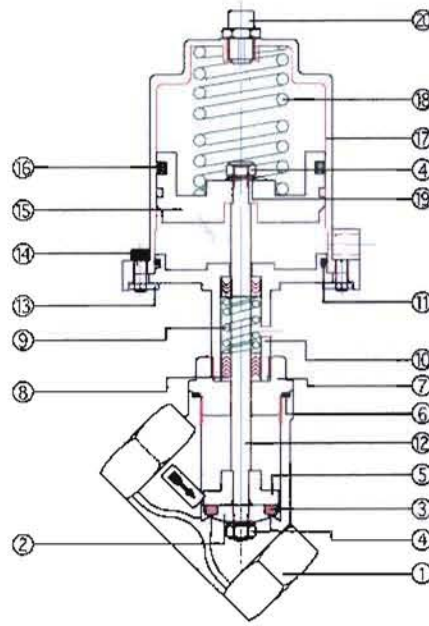

材質表 General material

NO	名稱	材質
1	BODY	SS316
2	GASKET	SS316
3	GASKET	PTFE
4	NUT	SS316
5	SEAT	SS304
6	GASKET	PTFE
7	VALVE NUT	SS316
8	V-GASKET	PTFE
9	SPRING	SS304
10	CYLINDER BASE	SS316
11	O-RING	NBR
12	SHAFT	SS316
13	FIXED NUT	SS304
14	SCREW	SS304
15	PISTON	AL
16	UHS-RING	NBR
17	CYLINDER	SS316
18	SPRING	STEEL
19	WASHER	SS304
20	BREATHE NUT	SS304

尺寸表 Dimension

SIZE		A	B	C	E	G	操作壓力 OPERATING PRESSURE (kg/cm ²)	單重 (kg)
mm	w							
15	1/2	65	195	160	93.5	11	3~10	1.8
20	3/4	75	200	165	93.5	12	3~10	1.9
25	1	90	210	170	93.5	14	3~10	2.1
32	1-1/4	110	245	215	120	22	3~10	4.3
40	1-1/2	120	250	220	120	22	3~10	5
50	2	150	270	230	120	22	3~10	6

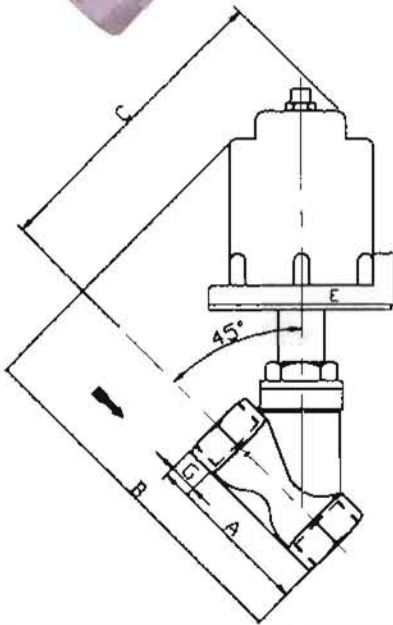

6000 PSI STAINLESS STEEL NEEDLE VALVES

ND-6000

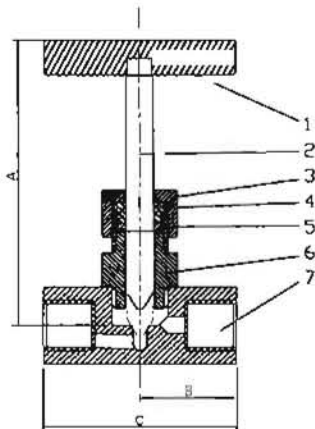

MATERIAL

SIZE	A	B	C	單重 (kg)
1/8	75	22.5	45	0.32
1/4	75	22.5	45	0.32
3/8	78	29.5	59	0.45
1/2	87	32.5	65	0.5
3/4	90	35	70	0.95
1	103	40	80	2.2

DIMENSIONS(mm)

NO	PARTS NAME	SPECIFICATION
1	HANDLE	SUS304
2	STEM	SS316
3	GLAND NUT	SS304
4	GLAND NUT	SS304
5	PACKING	TEFLON
6	BONNET	SUS304
7	BODY	ASTM A-351 GR.CP3M