

Pneumatic Actuators

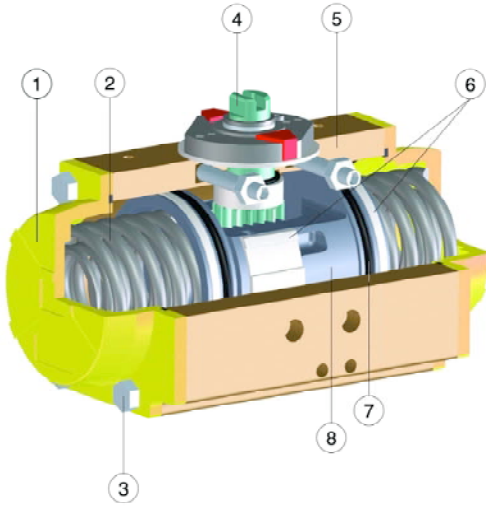

•NOMINAL VALUES:

Pressure rating max 115 PSI
 Temperature range:
 standard (-4°F;+185°F), high (-4°F;+302°F), low (-40°F;+185°F)
 Pre lubricated for life of actuator at assembly
 100% fully factory tested

•ROTATION ADJUSTMENT 0-90°:

From MOD. 52 up to 140
 •standard $\pm 5^\circ$ in both clockwise and counterclockwise direction by means of adjusting screws outside the internal air supply chambers
 •adjusting cam with plane faces for manual adjustments
 •standard visual position indicators
 MOD. 160-200-270
 •standard $\pm 5^\circ$ in counterclockwise direction by means of adjusting screws in the caps
 •kit for $\pm 5^\circ$ in clockwise direction available on request

1. DIE CAST ALUMINIUM END CAPS:

standard polyester powder coated
 Optional nickel-plated for corrosive environments (Contact Factory)

2. CONCENTRIC SPRING SETS:

Zinc phosphate treated
 High resistance and reliability
 Spring sets to suit different air pressure/torque requirements
 Extra long fasteners to allow safe dismantling for maintenance
 Same body dimensions for DA/SR versions

3. END CAP SCREWS/ADJUSTING SCREWS:

Stainless steel as standard

EXTERNAL CONNECTION:

Namur slotted shaft - in accordance with the international standard to provide a self-centering positive drive for positioners and switches.

Namur solenoid mounting - manufactured in accordance with this international standard permitting direct mounting of a wide variety of solenoid valves

4. PINION MADE IN STEEL:

One piece high strength alloy steel pinion shaft, precision machined gear teeth for precise fit, efficiency and long life. Standard pinion is electroless nickel coated for corrosion protection and is blowout proof. Optional stainless steel pinion shaft available.

5. EXTRUDED ALUMINIUM BODY UNI 6060:

Hard-coat anodized as standard finish 45-50 (micron)
 Good wear resistance
 High corrosion resistance
 Special finishes nickel-plating or epoxy coated

6. POM PISTON GUIDES:

Large contact area
 Low friction, self lubricating material
 Long life

7. SEALS

NBR standard version
 Viton® high temperature version
 SILICON low temperature version

8. PISTONS MADE FROM DIE CAST ALUMINIUM:

Chemical nickel plating upon request

TWIN RACK AND PINION DESIGN:

Constant torque output
 Compact design
 Balanced internal forces
 Robust design to ensure long life

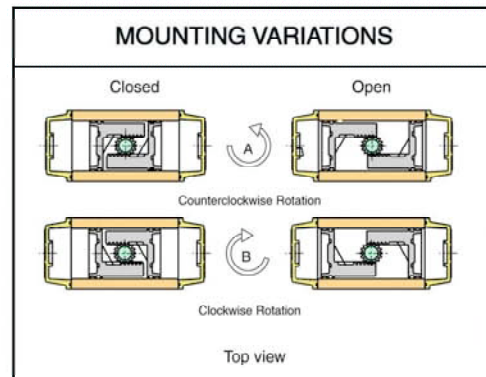
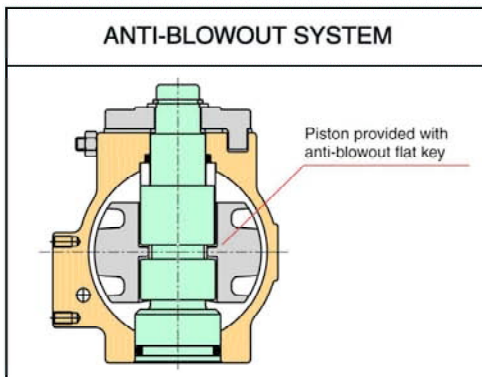

Actuators and Controls

**Models From
160-200-270**

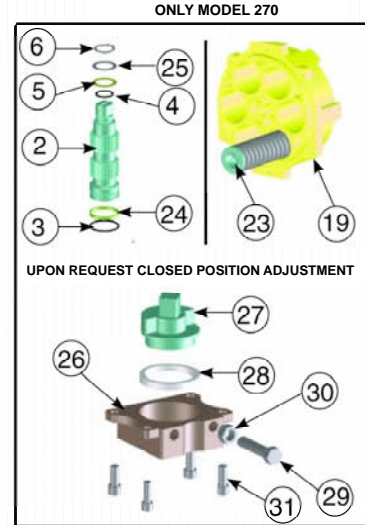
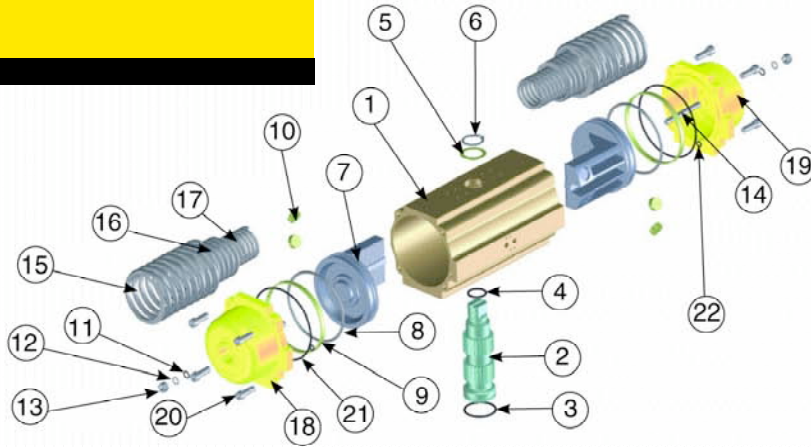

ITEM	DESCRIPTION	MATERIAL	TREATMENT	QTY. DA	QTY. SR
1	Body	Extruded aluminium	Hard anodized	1	1
2	Anti-blowout pinion	Steel	Nickel plated	1	1
• 3	Lower pinion o-ring	NBR		1	1
• 4	Top pinion o-ring	NBR		1	1
• 5	Pinion bearing top	POM		1	1
6	Pinion snap ring	Steel	Nickle plated	1	1
7	Piston	Die cast aluminium		2	2
• 8	Piston o-ring	NBR		2	2
• 9	Bearing piston head	PTFE 15% graphite		2	2
• 10	Bearing, piston back	POM		4 6	4 6
• 11	Stop bolt o-ring	NBR		2	2
12	Washer	Stainless steel		2	2
13	Travel stop nut	Stainless steel		2	2
14	Travel stop screw	Stainless steel		2	2
15	External spring	Steel	Zinc-phosphate	0	see spring setting at page xx
16	Central spring	Steel	Zinc-phosphate	0	
17	Internal spring	Steel	Zinc-phosphate	0	
18	Left end cap	Die cast aluminium	Painted	1	1
19	Right end cap	Die cast aluminium	Painted	1	1
20	End cap screw	Stainless steel		8 12	8 12
21	End cap o-ring - large	NBR		2	2
22	End cap o-ring - small	NBR		2	2
23***	Precompressed spring	Steel	Zinc-phosphate	0	see spring setting at page xx
24***	Bearing	PTFE 15% graphite		1	1
• 25***	Pinion washer	Stainless steel		1	1
UPON REQUEST CLOSED POSITION ADJUSTMENT					
26	Plate	GGG40	Painted	1	1
27	Coupling	Steel	Nickel plated	1	1
• 28	Antifriction ring	PTFE		1	1
29	Stop screw	Steel	Zinc plated	1	1
30	Stop bolt retaining nut	Stainless steel		1	1
31	Fixing screws	Stainless steel		4	4

6

• Parts subject to wear **6,12, ***** Valid for model 270 only

'Apollo' Valves

Dimensions Models 32-160-200-270

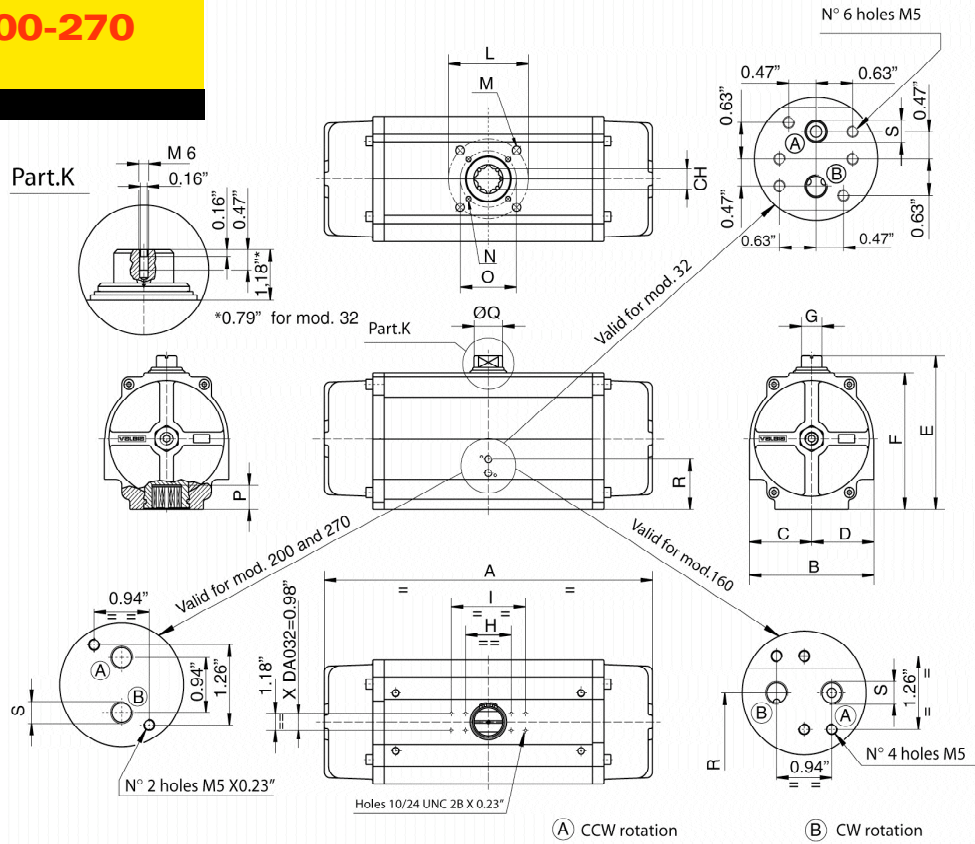

MOD.	DRILLING ISO 5211	CH	A	B	C	D	E	F	G	H	I	L	M	N	O	P	ØQ	R	S NPT	T	U	V	W
32	F03	0.394	4.33	1.77	0.89	0.89	2.56	1.77	0.39	1.97	-	1.42	10-24 UNC 2BX0.29"	-	-	0.47	0.46	-	1/8"	-	-	-	-
160	F10-F12	1.066	20.55	7.36	3.43	3.94	8.58	7.40	1.18	3.15	5.12	4.92	1/4"-20 UNC 2BX0.71"	3/8-16 UNC 2BX0.59	4.02	1.26	1.38	3.21	1/4"	6.30	1.77	2.20	2.50
200	F14	1.417	22.64	8.58	4.29	4.29	10.59	9.41	1.42	3.15	5.12	5.51	5/8"-11 UNC 2BX0.98"	-	-	1.54	1.97	3.46	1/4"	7.48	2.03	2.52	3.11
270	F16	1.81	26.46	11.42	5.71	5.71	14.21	13.03	1.42	3.15	5.12	6.50	3/4"-10 UNC 2BX1.18"	-	-	2.05	1.97	4.76	1/4"	9.06	2.68	3.11	4.37

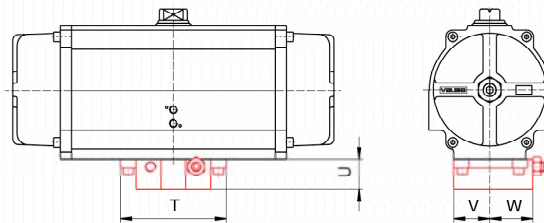

Optional Closed Position Adjustment

Double Acting Actuator

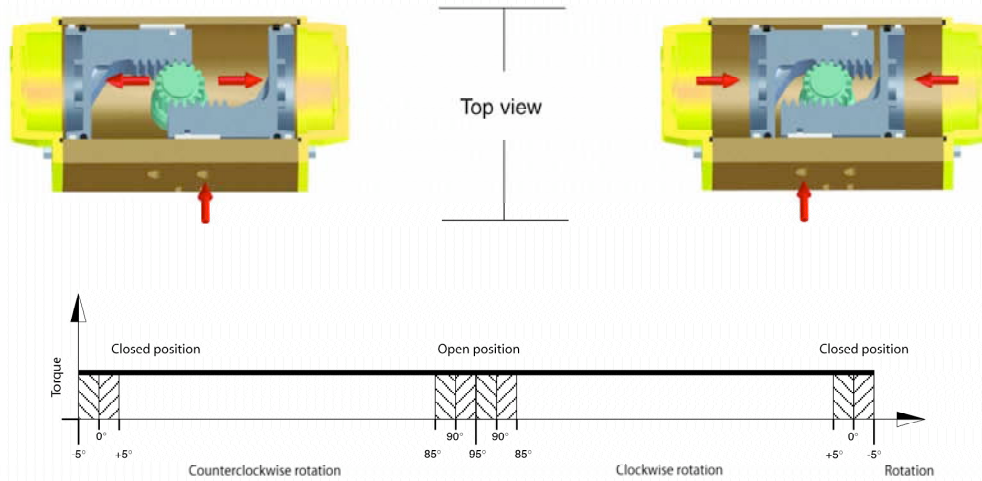

With reference to the above diagram it can be noted that the torque of a double acting actuator remains constant throughout the complete cycle. The user can decide which model to choose according to their own specific requirements, using the following guidelines:

1. Define the maximum torque of the valve to automate.
2. To obtain a safety factor, increase the torque value chosen by 25%-50% (subject to the type of valve and working conditions).
3. Once the torque value is obtained consult the torque chart in the corresponding air pressure column, find a torque value exceeding the valve requirement.
4. Once the torque value is determined, move horizontally to the column "model" to find the actuator model required.

MODEL	AIR SUPPLY PRESSURE (PSI)							
	40	50	60	70	80	90	100	115
	TORQUE OUTPUT DOUBLE ACTING ACTUATORS (in-Lbs)							
DA 32	34	43	55	64	71	82	87	101
DA 52	86	110	133	156	179	203	226	261
DA 63	154	196	238	280	321	363	405	468
DA 75	284	360	435	511	586	661	737	850
DA 85	408	518	629	740	851	962	1072	1238
DA 100	646	818	991	1163	1336	1508	1681	1939
DA 115	1070	1355	1640	1925	2210	2495	2780	3208
DA 125	1409	1783	2157	2532	2906	3280	3654	4216
DA 140	2009	2511	3013	3515	4018	4513	5015	5772
DA 160	2930	3662	4394	5127	5859	6591	7324	8422
DA 200	5488	6866	8239	9612	10981	12359	13732	15792
DA 270	12734	15919	19097	22284	25469	28654	31832	36611

Spring Return Actuator

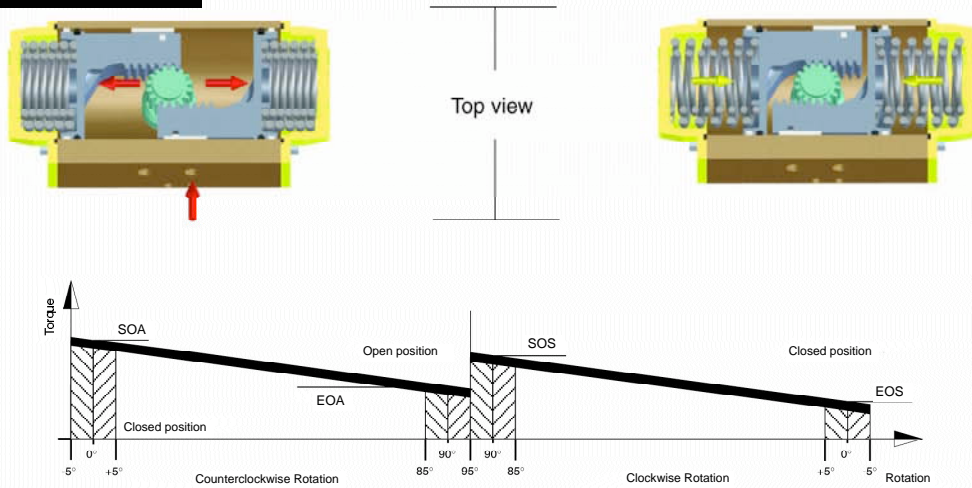

The torque given by the actuator is defined by four fundamental values.

Opening Rotation

SOA = Start of air stroke
EOA = End of air stroke

Closing Rotation

SOS = Start of spring stroke
EOS = End of spring stroke

The user can decide which model to choose according to their own specific requirements using the following guidelines:

1. Define the maximum torque of the valve to automate.
2. To obtain a safety factor increase the torque value chosen by 25% - 50% (subject to the type of valve and working conditions).
3. Once the torque value is obtained, consult the torque chart in the corresponding air pressure column, find the torque value exceeding the valve requirements, taking into account of the lower value between the SOS and EOA values.
4. Once the torque value is determined, move horizontally to the column "model" to find the actuator model required.

VALID FROM MODEL 52 TO 140		
SPRING SETTING		
SET	EXTERNAL SPRING	INTERNAL SPRING
01	1	1
02	2	-
03	1	2
04	2	1
05	2	2

VALID FOR MODEL 160 AND 200			
SPRING SETTING			
SET	EXTERNAL SPRING	CENTRAL SPRING	INTERNAL SPRING
01	-	2	-
02	2	-	-
03	1	2	-
04	2	-	2
05	2	2	-
06	2	2	2

VALID FOR MODEL 270	
SPRING SETTING	
PRETENSIONED SPRING	
SET	N° OF SPRINGS FOR EACH SIDE
01	2/3
02	3/3
03	3/4
04	4/4
05	4/5
06	5/5
07	5/6
08	6/6

Actuators and Controls

Torque Output SR Actuators

MOD.	SET	SPRING TORQUE (In-Lbs)		AIR SUPPLY PRESSURE (PSI)															
				40		50		60		70		80		90		100		115	
		0° EOA	90° SOA	0° SOA	90° EOA	0° SOA	90° EOA	0° SOA	90° EOA	0° SOA	90° EOA	0° SOA	90° EOA	0° SOA	90° EOA	0° SOA	90° EOA	0° SOA	90° EOA
SR52	01	32	44	48	23	72	47	95	70										
	02	42	59			61	31	84	54	108	77								
	03	46	66					80	47	104	70	127	94	150	117				
	04	57	82					70	31	93	55	116	78	140	101	163	125		
	05	72	105							78	32	101	55	125	78	148	102	183	137
SR63	01	44	85	92	38	134	80	176	122										
	02	58	109			120	56	162	98	204	140								
	03	71	128					149	79	191	121	233	162	275	204				
	04	85	152					136	54	177	96	219	138	261	180	303	222		
	05	111	196							151	53	193	95	235	136	276	178	339	241
SR75	01	89	172	168	63	244	138	319	214										
	02	118	226			215	85	291	160	366	235								
	03	133	249					275	137	351	212	426	288	502	363				
	04	162	303					247	83	322	158	398	234	473	309	549	385		
	05	205	380							279	81	354	157	430	232	505	308	618	421
SR85	01	143	242	238	109	349	219	460	330										
	02	176	298			316	163	427	274	537	384								
	03	215	361					387	211	498	322	609	432	720	543				
	04	248	417					354	155	465	265	576	376	687	487	797	633		
	05	321	536							392	146	503	257	614	368	725	478	891	645
SR100	01	218	395	384	154	556	326	728	499										
	02	288	521			485	199	658	372	830	544								
	03	318	564					628	329	801	502	973	674	1146	847				
	04	389	691					558	203	730	375	903	548	1075	720	1248	893		
	05	489	860							630	206	802	378	975	551	1147	723	1406	982
SR115	01	363	658	650	270	935	555	1220	840										
	02	449	835			848	378	1133	663	1419	949								
	03	538	957					1044	541	1329	827	1615	1112	1900	1397				
	04	625	1133					958	365	1243	650	1528	935	1813	1220	2098	1505		
	05	800	1432							1067	352	1352	637	1638	922	1923	1207	2350	1635
SR125	01	470	877	850	328	1224	703	1599	1077										
	02	560	1040			1135	539	1509	914	1883	1288								
	03	718	1313					1351	640	1725	1015	2099	1389	2474	1763				
	04	808	1477					1261	477	1636	851	2010	1226	2384	1600	2758	1974		
	05	1055	1913							1388	415	1762	789	2136	1164	2511	1538	3072	2099
SR140	01	726	1346	1240	508	1742	1010	2244	1512										
	02	815	1523			1642	821	2144	1323	2646	1825								
	03	1036	1958					1910	856	2412	1358	2914	1861	3408	2355				
	04	1134	2126					1810	668	2312	1170	2814	1672	3308	2166	3810	2668		
	05	1453	2728							1979	515	2481	1017	2975	1511	3477	2013	4233	2769
SR160	01	885	1345	1921	1390	2644	2140												
	02	1301	1991			2228	1503	2952	2217										
	03	1531	2336			1980	1131	2713	1854	3419	2569								
	04	1770	2841					2447	1350	3162	2074	3886	2779						
	05	2230	3327							2737	1507	3452	2240	4175	2963				
	06	2655	4186									2983	1443	3715	2167	4421	2828	5475	3865
SR200	01	1540	2168	3718	2904	5069	4317												
	02	2186	3150			4414	3308	5770	4681										
	03	2637	3752			3936	2591	5301	4035	6639	5400								
	04	3124	4699					4788	3080	6126	4445	7486	5795						
	05	3726	5327							5453	3613	6822	5008	8182	6385				
	06	4664	6867									5893	3539	7288	4925	8591	6175	10562	8137
SR270	01	4469	6973	8574	6017	11883	9317	15309	12743										
	02	5363	8372	7619	4548	10928	7857	14353	11283										
	03	6257	9761	6672	3088	9972	6388	13398	9814	16824	13240								
	04	7150	11159	5716	1619	9016	4928	12442	8353	15877	11779	19177	15080						
	05	8044	12549			8069	3459	11495	6884	14921	10310	18221	13619	21530	16920				
	06	8938	13947					10539	5415	13965	8850	17274	12150	20574	15459				
	07	9832	15336					9584	3955	13009	7381	16319	10681	19619	13990	23053	17416		
	08	10735	16735					8637	2486	12063	5912	15363	9221	18672	12521	22098	15947	27115	20965

Actuators and Controls

Technical Data

WORKING TIME (SEC.)														
TYPE	MODEL	32	52	63	75	85	100	115	125	140	160	200	270	
		ROTAT. 0° - 90°	COUNTERCLOCKWISE ROTATION (DA)	CCW	0.03	0.03	0.06	0.12	0.20	0.30	0.53	0.83	0.98	1.15
CLOCKWISE ROTATION (DA)	CW		0.03	0.04	0.08	0.12	0.19	0.27	0.47	0.66	0.93	1.10	1.070	4.50
COUNTERCLOCKWISE ROTATION (SR)	CCW		-	0.09	0.14	0.22	0.31	0.44	0.83	1.08	1.23	1.75	2.38	4.50
CLOCKWISE ROTATION (SR)	CW		-	0.09	0.14	0.22	0.33	0.46	0.78	0.90	0.97	1.34	2.19	6.20

Approximative times obtained at the pressure of 87 PSI without valve

WEIGHT CHART (Lbs)													
TYPE	MODEL	32	52	63	75	85	100	115	125	140	160	200	270
DA 90°		1.08	2.25	3.26	5.51	7.39	11.02	17.75	22.09	33.86	43.21	70.99	154.00
SR 90°		-	2.62	3.97	6.94	9.37	14.40	23.92	26.76	45.28	65.04	111.00	192.79

ACTUATOR AIR CONSUMPTION CHART (in cubic inches per stroke)														
TYPE	MODEL	32	52	63	75	85	100	115	125	140	160	200	270	
ROTAT. 0° - 90°	COUNTERCLOCKWISE ROTATION (DA/SR)	CCW	2.44	6.10	11.50	21.97	31.12	48.21	78.72	99.47	137.91	220.30	347.84	915.36
	CLOCKWISE ROTATION (DA)	CW	1.83	7.93	14.04	26.85	39.06	61.02	104.35	134.86	192.84	290.47	599.86	1086.22