



77-100 Series Bronze Full Port Ball Valve



Threaded, 600 psig WOG, Cold Non-Shock. 150 psig Saturated Steam. (See referenced P/T chart)
Vacuum Service to 29 inches Hg.

Federal Specification: WW-V-35C, Type: II, Composition: BZ, Style: 3.

MSS SP-110; Ball Valves Threaded, Socket-Welding, Solder Joint, Grooved and Flared Ends.

FEATURES

- Two-piece body
- Reinforced seats
- Mounting pad for easy actuator mounting
- Blow-out-proof stem design
- Adjustable packing gland
- Full port for full flow & min. pressure drop

STANDARD MATERIAL LIST

1. Lever and grip	Steel, zinc plated w/vinyl	10. Body seal	PTFE (1-1/4" to 2-1/2")
2. Stem packing	MPTFE	11. Body	B584-C84400
3. Stem bearing	RPTFE		
4. Ball	B16, chrome plated		
5. Seat (2)	RPTFE		
6. Retainer	B16 (1/4" to 1") B584-C84400 (1-1/4" to 2-1/2")		
7. Gland nut	B16		
8. Stem	B16		
9. Lever nut	Steel, zinc plated		

VARIATIONS AVAILABLE:

77-140 Series (316 SS Ball & Stem)

77-190 Series (Locked Retainer)

OPTIONS AVAILABLE:

(SUFFIX)	OPTION	SIZES
-02-	Stem Grounded	1/4" to 2-1/2"
-03-	1-1/4" CS Stem Extension	1/4" to 2-1/2"
-04-	2-1/4" CS Stem Extension	1/4" to 2-1/2"
-05-	Plain Ball	1/4" to 2-1/2"
-07-	Steel Tee Handle	1/4" to 1-1/4"
-08-	90° Reversed Stem	1/4" to 2-1/2"
-10-	SS Lever & Nut	1/4" to 2-1/2"
-11-	Therma-Seal™ Insulating Tee Handle	1/4" to 2"
-14-	Side Vented Ball (Uni-Directional)	1/4" to 2-1/2"
-15-	Wheel Handle, Steel	1/4" to 1-1/4"
-16-	Chain Lever - Vertical	3/4" to 2-1/2"
-17-	Rough Chrome Plated - Bronze Valves	1/4" to 2-1/2"
-18-	Plain Yellow Grip	1/4" to 2-1/2"
-20-	Slot Vented Ball	1/4" to 2-1/2"
-21-	UHMWPE Trim (Non-PTFE)	1/4" to 2-1/2"
-24-	Graphite Packing	1/4" to 2-1/2"
-27-	SS Latch-Lock Lever & Nut	1/4" to 2-1/2"
-28-	Mounting Pad Not Drilled & Tapped	1/4" to 2-1/2"
-30-	Cam-Lock and Grounded	1/4" to 1-1/4"
-32-	SS Tee Handle & Nut	1/4" to 1-1/4"
-35-	VTFE Trim	1/4" to 2-1/2"
-36-	SS High-Rise Round Handle & Nut	1/4" to 1-1/4"
-40-	Cyl-Loc and Grounded	1/4" to 1-1/4"
-45-	Less Lever & Nut	1/4" to 2-1/2"
-46-	Latch Lock Lever - Lock in Closed Position Only	1/4" to 2-1/2"
-47-	SS Oval Latch-Lock Handle & Nut	1/4" to 3/4"
-48-	SS Oval Handle (No Latch) & Nut	1/4" to 2"
-49-	Assembled Dry	1/4" to 2-1/2"
-50-	2-1/4" CS Locking Stem Extension	1/4" to 2-1/2"
-56-	Multifill Seats & Packing	1/4" to 2-1/2"
-57-	Oxygen Cleaned	1/4" to 2-1/2"
-58-	Chain Lever - Horizontal	3/4" to 2-1/2"
-60-	Static Grounded Ball & Stem	1/4" to 2-1/2"
-63-	NPT x Solder/Socket Weld	1/4" to 2-1/2"
-64-	250# Steam Trim	1/4" to 2-1/2"
-92-	Balancing Stop	1/4" to 2-1/2"
-P01-	BSPP (Parallel) Thread Connection	1/4" to 2-1/2"
-T01-	BSPT (Tapered) Thread Connection	1/4" to 2-1/2"
-SV-	Safety Vent (H-12)	1/4" to 2"

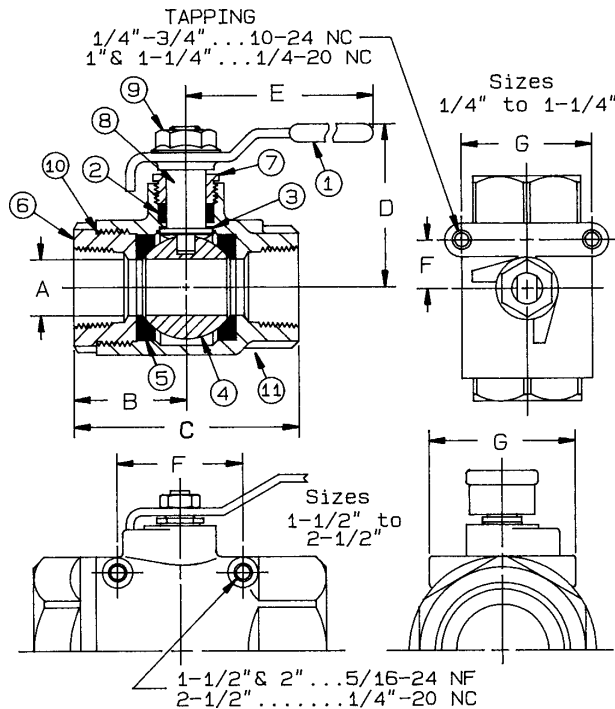

BRONZE FULL PORT BALL VALVE

NUMBER	SIZE	A	B	C	D	E	F	G	Wt.
77-101-01	1/4"	.43	1.09	2.18	1.77	3.87	.50	1.12	.79
77-102-01	3/8"	.50	1.09	2.18	1.77	3.87	.50	1.12	.75
77-103-01	1/2"	.50	1.09	2.18	1.77	3.87	.50	1.12	.69
77-104-01	3/4"	.81	1.56	3.12	2.17	4.87	.87	1.37	1.83
77-105-01	1"	1.00	1.81	3.62	2.68	5.50	.93	1.50	3.32
77-106-01	1-1/4"	1.25	2.12	4.25	2.90	5.50	.93	1.50	5.05
77-107-01	1-1/2"	1.50	2.37	4.75	3.10	8.00	2.08	3.06	6.71
77-108-01	2"	2.00	2.65	5.37	3.50	8.00	2.41	3.52	11.75
77-109-01	2-1/2"	2.50	3.25	6.50	4.06	8.00	2.75	3.37	17.25

For Pressure/Temperature Ratings,
Refer to Page M-8, Graph No. 4

FLOW DATA

For Apollo® Ball Valves

The listed Cv "factors" are derived from actual flow testing, in the Apollo® Ball Valve Division, Conbraco Industries, Inc., Pageland, South Carolina. These tests were completed using standard "off the shelf" valves with no special preparation and utilizing standard schedule 40 pipe. It should be understood that these factors are for the valve only and also include the connection configuration. The flow testing is done utilizing water as a fluid media and is a direct statement of the gallons of water flowed per minute with a 1 psig pressure differential across the valve/connection unit. Line pressure is not a factor. Because the Cv is a factor, the formula can be used to estimate flow of most media for valve sizing.

Flow of Liquid

$$Q = Cv \sqrt{\frac{\Delta P}{SpGr}}$$

$$\text{or } \Delta P = \frac{(Q)^2 (SpGr)}{(Cv)^2}$$

Where:

Q = flow in US gpm
 ΔP = pressure drop (psig)
 SpGr = specific gravity at flowing temperature
 Cv = valve constant

Flow of Gas

$$Q = 1360 Cv \sqrt{\frac{(\Delta P) (P_1)}{(SpGr) (T)}}$$

$$\text{or } \Delta P = \frac{5.4 \times 10^{-7} (SpGr) (T)}{(Q)^2} (Cv)^2 (P_2)$$

Where:

Q = flow in SCFH
 ΔP = pressure drop (psig)
 SpGr = specific gravity (based on air = 1.0)
 P₁ = outlet pressure-psia (psig + 14.7)
 T = (temp. °F + 460)
 Cv = valve constant

Cv FACTORS

SERIES:

70-100, 71-100, 71AR, 73A-100,
 74-100, 76-100, 76AR, 80-100
 81-100, 89-100

SIZE		1/4"	3/8"	1/2"	3/4"	1"	1-1/4"	1-1/2"	2"	2-1/2"	3"	4"
OPEN	90°	8.4	7.2	15	30	43	48	84	108	503	370	670

Cv FACTORS

76F, 77, 77AR, 77C, 77D SERIES

SIZE		1/4"	3/8"	1/2"	3/4"	1"	1-1/4"	1-1/2"	2"	2-1/2"
OPEN	90°	8.1	15	15	51	68	125	177	389	503

Cv FACTORS

82-100/200, 83R-100/200/700, 85R-100/200, 86R-100/200/700, 83-500/600, 86-500/600/900 SERIES

SIZE		1/4"	3/8"	1/2"	3/4"	1"	1-1/4"	1-1/2"	2"	2-1/2"	3"	4"
OPEN	90°	8.1	14	26	51	68	120	170	376	510	996	1893

Cv FACTORS

83A/83B, 86A/86B, 86C SERIES

SIZE		1/4"	3/8"	1/2"	3/4"	1"	1-1/4"	1-1/2"	2"
OPEN	90°	8.1	14	26	51	68	120	170	376

400# Bronze P-T Rating (Graph 3)

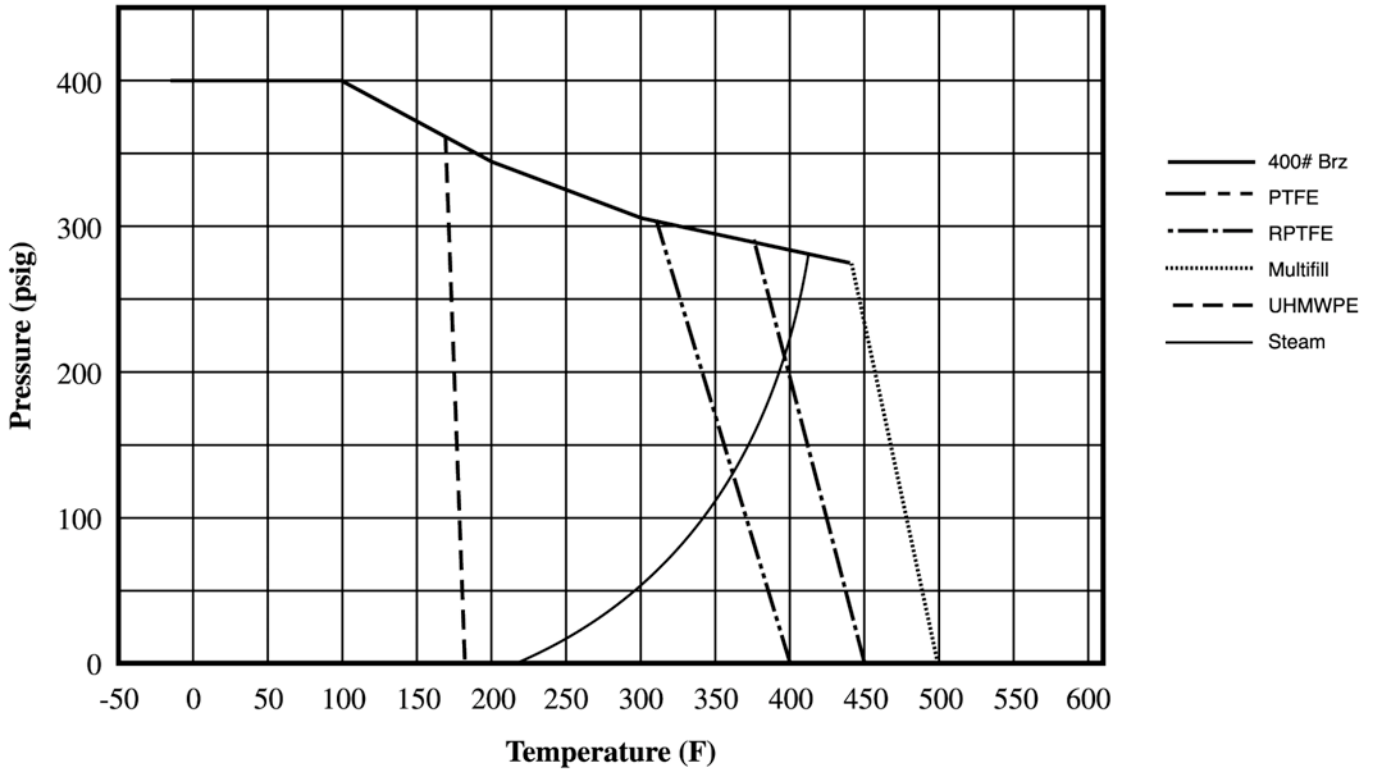

600# Bronze P-T Rating (Graph 4)

