

Apollo® 70-140-64 Series

Threaded Bronze 250 Lb. Steam Valve

Threaded, 600 psig WOG, Cold Non-Shock. 250 psig Saturated Steam.

Vacuum Service to 29 inches Hg.

Federal Specification: WW-V-35C, Type: II, Composition: BZ, Style: 3.

FEATURES

- 316 SS ball and stem
- Multifill seats
- Multifill stuffing box ring
- Blow-out-proof stem design
- Adjustable packing gland

STANDARD MATERIAL LIST

1. Lever and grip	Steel, zinc plated w/vinyl	7. Gland nut	B16
2. Stem packing	Multifill PTFE	8. Stem	A276-316
3. Stem bearing	RPTFE	9. Lever nut	Steel, zinc plated
4. Ball	A276-316	10. Body seal	PTFE
5. Seat (2)	Multifill PTFE		(1-1/4" to 3")
6. Retainer	B16 (1/4" to 1")	11. Body	B584-C84400
	B584-C84400 (1-1/4" to 3")		

Valves with -64 trim feature a yellow vinyl grip with distinctive red lettering.

These valves are recommended for saturated steam to 250 psig. They are also recommended for services with fluids with widely varying temperatures and / or high thermal expansion rates.

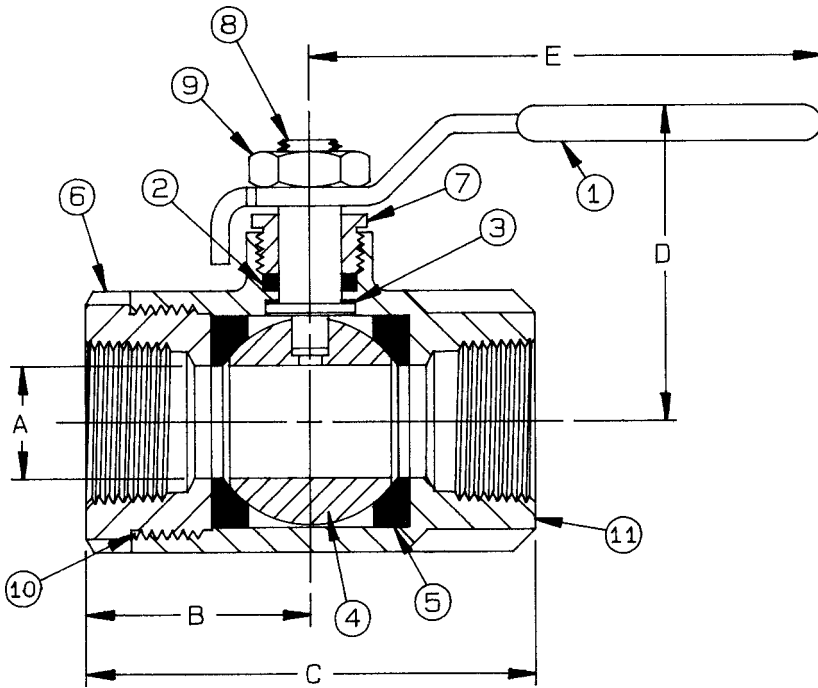

THREADED BRONZE 250 Lb. STEAM BALL VALVE

NUMBER	SIZE	A	B	C	D	E	Wt.
70-141-64	1/4"	.37	1.03	2.06	1.75	3.87	.59
70-142-64	3/8"	.37	1.03	2.06	1.75	3.87	.55
70-143-64	1/2"	.50	1.12	2.25	1.75	3.87	.62
70-144-64	3/4"	.68	1.50	3.00	2.12	4.87	1.37
70-145-64	1"	.87	1.68	3.37	2.25	4.87	1.71
70-146-64	1-1/4"	1.00	2.00	4.00	2.62	5.50	3.20
70-147-64	1-1/2"	1.25	2.18	4.37	3.06	8.00	4.53
70-148-64	2"	1.50	2.34	4.68	3.25	8.00	5.88
70-149-64	2-1/2"	2.50	3.25	6.50	4.12	8.00	17.03
70-140-64	3"	2.50	3.37	6.75	4.12	8.00	18.25

For Pressure/Temperature Ratings, Refer to Page N-10, Graph No. 4