

PNEUMATIC CONTROL VALVES PV16G

(V16G globe valves series with linear actuators PA series)

DESCRIPTION

The PV16G control valves are single seated, two-way body constructed with in-line straight connections. The PA pneumatic actuator is rubber diaphragm and multi-springs. Its action can be DA -direct action (air to close) or RA-reverse action (air to open). The PV16G valves have been designed to assure an accurate control in any process condition. Their wide application ranges allows the use of this valve with the most common process fluids such as water, superheated water, steam, air, gas and other non corrosive fluids.

MAIN FEATURES

Single seated, two ways, direct or reverse action valve.
Valve top flange permanently attached to the body, removal is unnecessary for replacing the actuator.
Soft sealing as standard.

OPTIONS: Balanced plug (sizes DN125-DN200)
 Position transmitter 4-20 mA
 Pneumatic pilot positioner
 Electropneumatic pilot positioner
 Air filter regulator
 Top-work manual handwheel
 Stainless steel construction.

USE: Saturated and superheated steam.
 Hot and superheated water.
 Air, gases and other noncorrosive fluids.

AVAILABLE MODELS: PV16G-single seat unbalanced.
 PV16G2-single seat,pressure balanced.

VALVE SIZES: DN15 to DN200

CONNECTIONS: Flanged EN 1092-2 PN16

ACTUATORS: PA-205; PA-280; PA-340; PA-435

ACTUATOR CONN: 1/4" NPT-F

CONTROL SIGNAL: 0,2 - 1 bar ; 0,4 - 1,2 bar ; 0,4 - 2 bar.

HOW TO SELECT: Never size the valve according to the pipe diameter in which it has to be fitted but according to the required actual flow of steam or water.Refer to valve calculation data sheet or consult the factory.



VALVE LIMITING CONDITIONS: Body design conditions: PN16
 16 bar at 120°C
 14,7 bar at 200°C
 Min.working temperature: -10°C

MAX. AIR SUPPLY PRESSURE: 3,5 bar

AMBIENT TEMPERATURE: -20°C ...+70°C

BONNET : From -5°C to +220°C (standard)

STEM SEALING: PTFE/GR V-Rings - up to 220°C (Standard bonnet)
 Graphite - up to 400°C (Standard on valves DN125-200)

PLUG CHARACT.: EQP - Equal percentage
 PT - On-off

PLUG DESIGN: Contoured

PORT : Full port

CE MARKING (PED - European Directive 97/23/EC)	
PN 16	Category
DN15 to DN50	SEP - art. 3, paragraph3
DN65 to DN200	1 (CE Marked)

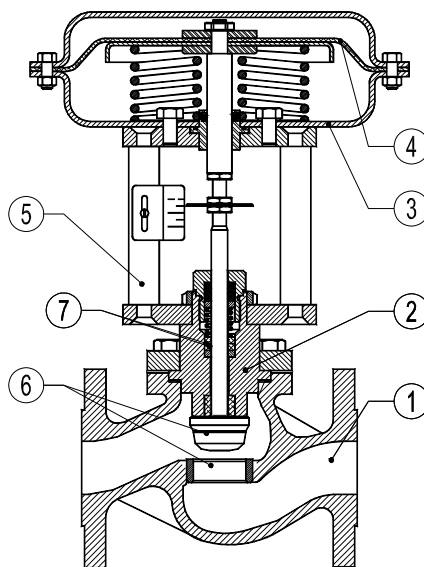
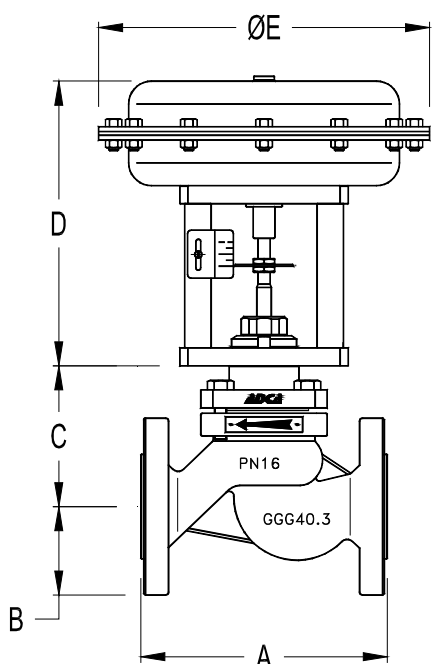

PV16 DA – Direct action

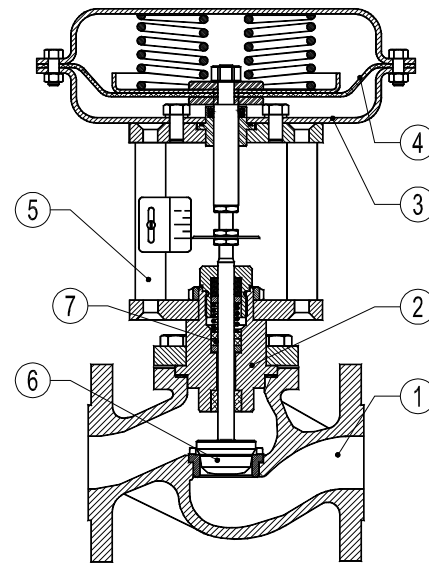

PV16 RA – Reverse action

DIMENSIONS - VALVE BODY				
DN	A (mm)	B (mm)	C (mm)	WEIGHT Kgs
15	130	48	80	3
20	150	53	80	3,7
25	160	58	85	4,4
32	180	70	90	6,8
40	200	75	105	9,5
50	230	83	105	11,7
65	290	93	165	18,5
80	310	100	175	20,3
100	350	110	190	30
125	400	125	240	-
150	480	142	290	-
200	600	170	315	-

MATERIALS		
POS.	DESIGNATION	MATERIAL
1	Valve Body	GJS-400-18-LT / 0.7043
2	Bonnet	CF8 / 1.4308
3	Actuator (Steel)	S235JRG2 / 1.0038
	Actuator (Stainless steel)	AISI304 / 1.4301
4	Diaphragm	NBR 70
5	Yoke (Steel)	C45E / 1.1191
	Yoke (Stainless steel)	AISI304 / 1.4301
6	Valve Seal	PTFE/GR
7	Standard packing	PTFE/GR

DIMENSIONS - ACTUATOR					
Type	Ø E (mm)	D (mm)			WEIGHT Kgs
		DN15-100 DA/RA	DN125-200 DA		
PA-205	210	235	—	5,7	
PA-280	275	240	—	8,8	
PA-340	335	265	—	14,3	
PA-435	430	295	—	24,5	

PV16 DA - Direct action from DN15 to DN200
 PV16 RA - Reverse action from DN15 to DN100

FLOW RATE COEFFICIENTS												
	SIZES											
	DN15	DN20	DN25	DN32	DN40	DN50	DN65	DN80	DN100	DN125	DN150	DN200
Kvs	3,8	5,1	9,4	15,4	22,2	40,1	63,4	89,7	136,7	230,6	316,1	555,3

Kvs in m³/h , see data sheet IS PV10.00 E ; For conversion Kvs = Cv(US) x 0,855

ACTUATOR STROKE IN mm												
	SIZES											
	DN15	DN20	DN25	DN32	DN40	DN50	DN65	DN80	DN100	DN125	DN150	DN200
Stroke	20	20	20	20	20	20	30	30	30	40	40/50	50



STEAM EQUIPMENT

MAX. PERMISSIBLE PRESS.DROP IN bar - Normally closed valve (fluid to open) -Reverse action actuator (air signal to open)

ACTUATOR	CONTROL SIGNAL	SIZES											
		DN15	DN20	DN25	DN32	DN40	DN50	DN65	DN80	DN100	DN125	DN150	DN200
PA-205	0,2 ÷ 1 bar	6	6	5	—	—	—	—	—	—	—	—	—
	0,4 ÷ 1,2 bar	10	10	7	—	—	—	—	—	—	—	—	—
	0,4 ÷ 2 bar	12	12	9	—	—	—	—	—	—	—	—	—
PA-280	0,2 ÷ 1 bar	28	26	16	8	6	3,5	—	—	—	—	—	—
	0,4 ÷ 1,2 bar	40	38	20	12	10	5	—	—	—	—	—	—
	0,4 ÷ 2 bar	50	45	25	16	12	6,5	—	—	—	—	—	—
PA-340A	0,2 ÷ 1 bar	60	60	50	20	12	10	—	—	—	—	—	—
	0,4 ÷ 1,2 bar	80	80	60	30	16	13	—	—	—	—	—	—
	0,4 ÷ 2 bar	100	100	80	40	20	18	—	—	—	—	—	—
PA-340B	0,2 ÷ 1 bar	—	—	—	—	—	—	4	2,5	1	—	—	—
	0,4 ÷ 1,2 bar	—	—	—	—	—	—	5	3,5	1,5	—	—	—
	0,4 ÷ 2 bar	—	—	—	—	—	—	6	4	2	—	—	—
PA435A	0,2 ÷ 1 bar	—	—	—	—	40	25	—	—	—	*	*	*
	0,4 ÷ 1,2 bar	—	—	—	—	48	30	—	—	—	*	*	*
	0,4 ÷ 2 bar	—	—	—	—	55	45	—	—	—	*	*	*
PA435B	0,2 ÷ 1 bar	—	—	—	—	—	—	6	5	3	*	*	*
	0,4 ÷ 1,2 bar	—	—	—	—	—	—	8	7	5	*	*	*
	0,4 ÷ 2 bar	—	—	—	—	—	—	10	8	6	*	*	*
	0,4 ÷ 2,5 bar	—	—	—	—	—	—	16	15	12	*	*	*

* For valve size DN125 and above please consult.

The pressure drop values are referred to closed valves. They have been verified by a control signal coming from an electro-pneumatic converter with an enduring minimum signal of 0,2 bar.

The actuator press. drops given with closed valve for the actuator signal 0,4 - 2 bar are also valid for ON-OFF service with air supply at 2,5 bar.

Special spring drops available on request.

The pressure drop values must be used within the body rating limits.

For electric actuator selection please consult catalogue IS EL.20.00 E or our technical department.

MAX.PERMISSIBLE PRESS.DROP IN bar - Normally open valve (fluid to open) - Direct action actuator (air signal to close)

ACTUATOR	CONTROL SIGNAL	SIZES											
		DN15	DN20	DN25	DN32	DN40	DN50	DN65	DN80	DN100	DN125	DN150	DN200
PA-205	0,2 ÷ 1 bar	16	16	12	5	—	—	—	—	—	—	—	—
	0,4 ÷ 2 bar	25	24	16	7,5	—	—	—	—	—	—	—	—
PA-280	0,2 ÷ 1 bar	—	—	19	10	8	4	—	—	—	—	—	—
	0,4 ÷ 2 bar	—	—	25	20	16	7	—	—	—	—	—	—
PA-340A	0,2 ÷ 1 bar	—	—	—	17	16	10	—	—	—	—	—	—
	0,4 ÷ 2 bar	—	—	—	28	26	25	—	—	—	—	—	—
PA-340B	0,2 ÷ 1 bar	—	—	—	—	—	—	5	3,5	1,5	—	—	—
	0,4 ÷ 2 bar	—	—	—	—	—	—	8	7	3	—	—	—
PA435B	0,2 ÷ 1 bar	—	—	—	—	—	—	8	5	3	*	*	*
	0,4 ÷ 2 bar	—	—	—	—	—	—	16	10	7,5	*	*	*

* For valve size DN125 and above please consult.

The actuator pressure drops given with closed valve, are obtained with the following air pressures supply :

Actuator signal 0,2 to 1 bar : air supply 1,2 bar

Actuator signal 0,4 to 2 bar : air supply 2,5 bar

The actuator press. drops given with closed valve for the actuator signal 0,4- 2 bar are also valid for ON-OFF service with air supply at 2,5 bar.

Special spring drops available on request.

The pressure drop values must be used within the body rating limits.

For electric actuator selection please consult catalogue IS EL.20.00 E or our technical department.

