

## FLOAT AND THERMOSTATIC STEAM TRAPS

### FLT17

(DN 1/2" to 1"; DN15 to DN25)

#### DESCRIPTION

FLT17 float and thermostatic (integral air vent) steam traps series are designed for all types of low and high pressure steam heating and process equipment.

Typical applications include unit heaters, heat exchangers, driers, jacketed vessels and all the applications where continuous drainage is essential.

Connections are female screwed or flanged for horizontal or vertical installation.

#### MAIN FEATURES

Modulating discharge.

Discharges condensate at steam temperature.

Unaffected by sudden or wide load and pressure changes.

Excellent air discharge (by thermostatic air vent).

#### OPTIONS:

SLR – steam lock release  
Equalizing plug or vent connection  
Internal strainer

#### USE:

Saturated and superheated steam.

#### AVAILABLE MODELS:

FLT17-4,5 , 10 and 14

#### SIZES:

DN 1/2" to DN1" – DN15 to DN25

#### CONNECTIONS:

Female screwed ISO7/1 Rp (BS21)

Flanged EN 1092-1/-2 PN16 or ANSI

#### INSTALLATION:

Standard horizontal installation –

From right to left FLT17 (R-L)

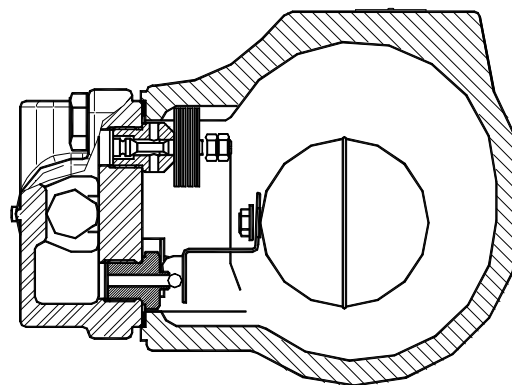

Upon request:

-horizontal installation with the flow from left to right (L-R)

-vertical installation with the flow from top to bottom (V)

#### MAX. DIFFERENTIAL PRESSURE

FLT17-4,5 : 4,5 bar

FLT17-10 : 10 bar

FLT17-14: 14 bar

#### BODY LIMITING CONDITIONS

FLANGED PN16*	FLANGED ANSI 150 **	RELATED TEMP.
ALLOW. PRES.	ALLOW. PRES.	
16 bar	15,4 bar	100 °C
15,5 bar	14,6 bar	150 °C
14,7 bar	13,8 bar	200 °C
13,9 bar	12,1 bar	250 °C

PMO - Max. operating pressure 14 bar

TMO - Max. operating temperature 198 °C

\* According to EN1092-2:2000 ; \*\* Acc. to EN1759-1:2004

Body limiting conditions PN16 or below, depending on the type of connection adopted. Rating PN16 for thread.

#### FLOW RATE CAPACITY IN Kgs/h

MODEL	SIZE	DIFFERENTIAL PRESSURE (bar)												
		0,5	1	1,5	2	3	4,5	6	7	8	9	10	12	14
FLT17-4,5	15 - 25	230	330	400	440	535	630							
FLT17-10	15 - 25	150	200	250	280	340	400	460	495	520	550	595		
FLT17-14	15 - 25	120	150	190	220	260	320	380	400	425	440	480	510	550

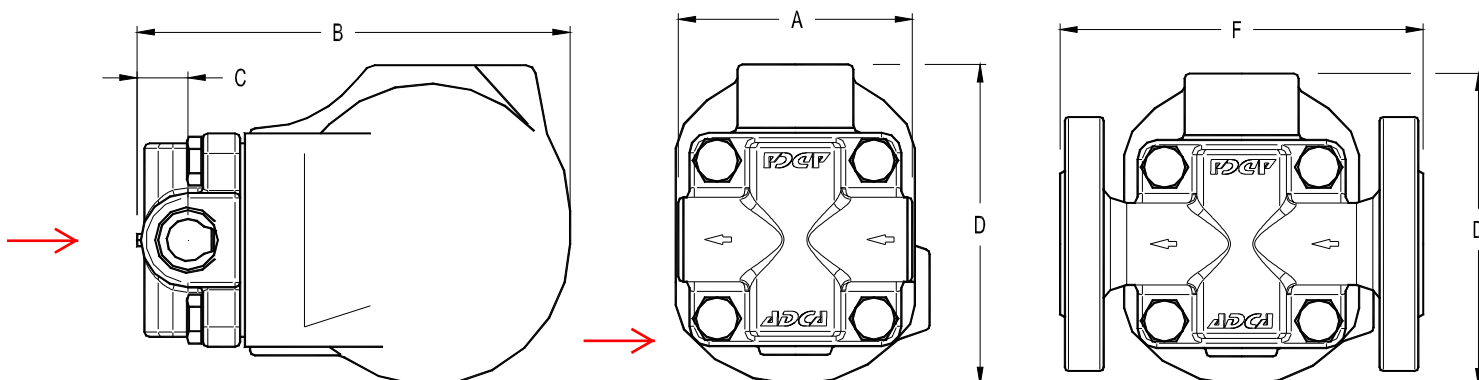

DIMENSIONS (mm)									
Screwed					EN PN16		ANSI 150		
SIZE DN	A	B	C	D	WGT. Kgs	F	WGT. Kgs	F	WGT. Kgs
15-1/2"	95	178	23	128	5,2	150	6,7	150	6,2
20-3/4"	95	178	23	128	5,2	150	7,2	150	6,4
25-1"	95	178	23	128	5,2	160	7,7	160	7,3

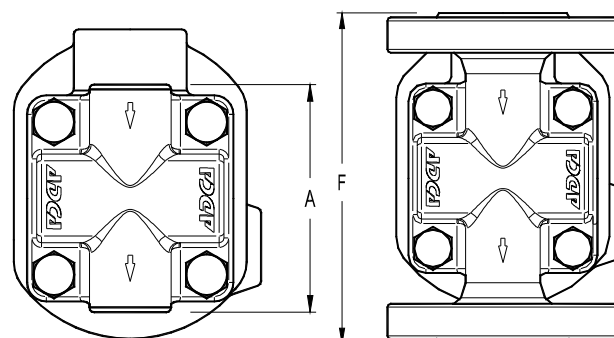
**Vertical Installation (V)**

MATERIALS		
POS.Nr.	DESIGNATION	MATERIAL
1	Body	GJS-400-15 / 0.7040
2	Cover	GJS-400-15 / 0.7040
3	*Gasket	Stainless st. / Graphite
4	*Seat	AISI 410 / 1.4006
5	*Valve	AISI 440C / 1.4125
6	*Lever	AISI 304 / 1.4301
7	*Float	AISI 304 / 1.4301
8	*Air vent	Stainless st. (Bimetallic)
9	Bolts	Steel 8.8

\*Available spare parts.

