

ADCAMAT POP and PPO14 How to select and size

SIZING OF THE SYSTEM

The discharge capacity of the pump is a function of:

1. Condensate load.....Kg/h
2. The pressure of operating medium (steam, compressed air or gas).
3. The total lift or back pressure the pump will have to exhaust against. This includes the change in fluid level elevation after the pump (0.0981bar/m of lift), plus pressure in the return piping, plus the pressure drop in bar caused by pipe friction, plus any other system component pressure drop the pump exhaust will have to overcome.
4. Filling head available (300 mm is recommended).

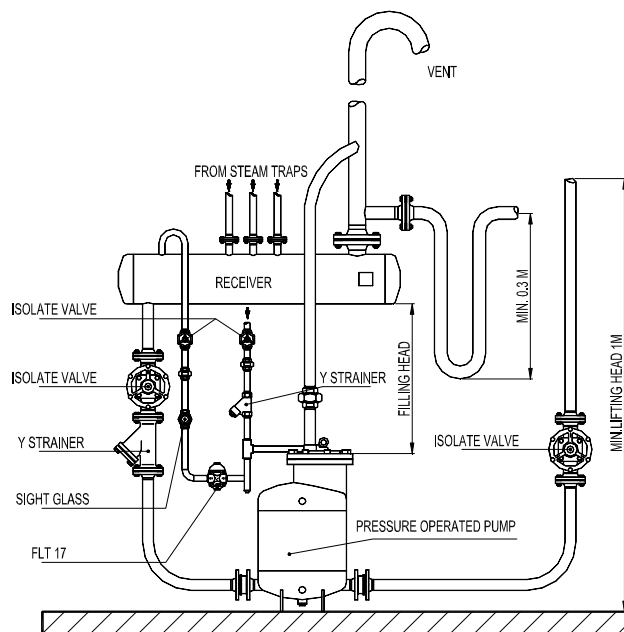

INSTALLATION

Fig.1 shows a typical example of installation of ADCAMAT automatic pump. For further details and instructions please contact the distributor.

RECEIVER

A receiver is recommended to temporarily hold the liquid and prevent any flooding of the equipment, while the pump is in the pumping cycle. A length of pipe of large diameter or a tank can also be used.

SUGGESTED RECEIVER				
PUMP SIZE	25	40	50	80 x 50
PIPE SIZE W/ 1m LENGTH	6"	8"	10"	12"

CAPACITY CORRECTION FACTOR FOR GASES OTHER THAN STEAM					
% Back press.vs. Motive Press.(BP/MP)	10%	30%	50%	70%	90%
Correction factor	1,04	1,08	1,12	1,18	1,28

Chart 2

CAPACITY MULTIPLYING FACTORS FOR OTHER FILLING HEADS				
Filling Head mm	PUMP SIZE			
	25	40	50	80 x 50
150	0,7	0,7	0,7	0,9
300	1	1	1	1
600	1,2	1,2	1,2	1,08
900	1,35	1,35	1,35	1,2

Chart 3

Motive Pressure bar	Total Lift bar	FLOW RATE IN Kg/h			
		Installation with 300 mm filling head above the pump cover			
		DN 25 x DN 25	DN 40 x DN 40	DN 50 x DN 50	DN 80 x DN 50
1	0,35	840	1490	2320	4480
2		1030	1520	3160	5240
3		1140	1640	3560	5640
4		1180	1680	3840	5840
5		1240	1740	3910	5900
6		1270	1760	3040	5980
8		1300	2200	3090	6030
10		1310	2205	4000	6080
2	1	805	1560	2550	4080
3		940	1790	2990	4720
4		1080	1930	3160	5080
5		1110	2010	3200	5280
6		1140	2090	3250	5400
8		1180	2190	3280	5490
10		1190	2200	3320	5560
3		2	780	1495	2470
4	900		1690	2620	3950
5	1000		1820	2830	4230
6	1040		1910	2860	4740
8	1100		2010	2880	4880
10	1110		2060	2900	4960
4	3	740	1400	2360	3480
5		860	1545	2540	3640
6		910	1675	2560	3720
8		970	1805	2590	4050
10		980	1850	2650	4110
5	4	720	1335	2280	2690
6		820	1480	2460	2860
8		910	1675	2500	3190
10		930	1760	2540	3380
6	5	680	1290	2080	2520
8		740	1530	2180	2740
10		810	1630	2220	2860
7	6	660	1230	1880	1940
8		730	1370	1940	2240
10		820	1490	2150	2360

Chart 1 (Based on liquid specific gravity 0,9 - 1,0)

Example:

Condensate load	1800 Kg/h
Filling head	150 mm
Motive fluid	Compressed air
Available pressure	8 bar
Vertical lift after pump	6 m
Return piping pressure	1,5 bar
Piping friction pressure drop	Negligible

Calculations:

Total back pressure: $1,5\text{bar} + (6\text{m} \times 0,0981) = 2,09\text{bar}$
 Pump choice, assuming steam as motive pressure at 8bar and a back pressure of 3bar, the DN50 pump has a capacity of 2590 kg/h according to Chart 1.

Correction for filling Head:

With 150 mm filling head the correction factor from chart 3 is 0,7. The corrected capacity is, $2590\text{Kgs/h} \times 0,7 = 1813\text{ kg/h}$

Correction for air as a motive fluid:

The % back pressure $2,09\text{bar}/8\text{bar} = 30\%$
 The correction factor from chart 2, is 1,08.
 The corrected capacity is, $1813\text{kg/h} \times 1,08 = 1958\text{Kg/h}$, and so a DN50 pump is still recommended.

PACKAGED AUTOMATIC PUMP UNIT (Suitable for steam supply)

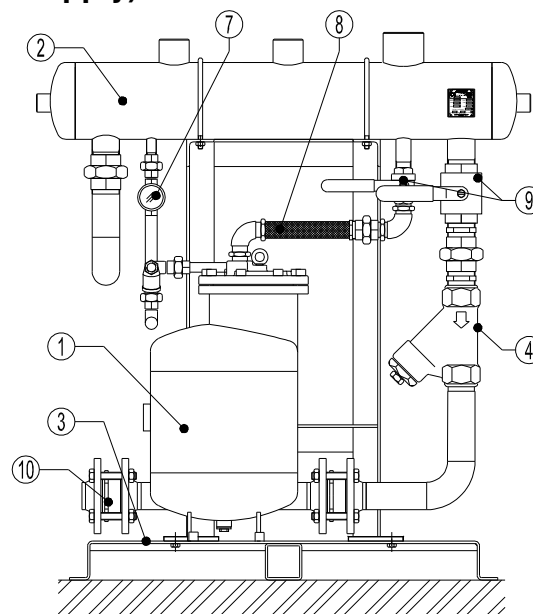
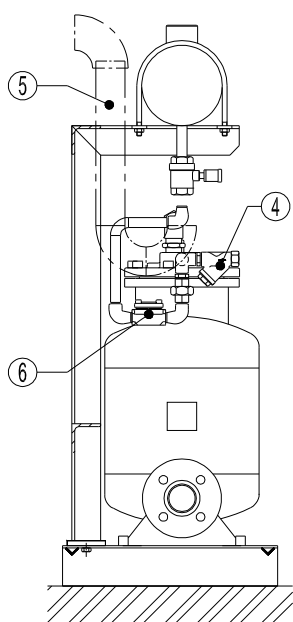

MATERIALS		
POS.	DESIGNATION	MODEL
1	Adcamat pump	POP or PPO series
2	Receiver	-
3	Metal frame	-
4	Y Strainer	IS16
5	Overflow	-
6	Steam trap	FLT or TH series
7	Sigh glass	SW
8	Flexible hose	St.Steel
9	Ball valve	St.Steel
10	Check valves	RD40

The ADCAMAT Packaged unit comprises an Adcamat POP or PPO14 pump, a vented receiver and all auxiliary items, compactly mounted on a metal frame piped and ready for connection.

Packaged units save time, work and site costs. In addition they ensure that installation of the pump is correct in every detail.

Two or more units can be connected in parallel to cope with flow rates beyond the capacity of a single pump. A DUPLEX PACKAGED assembly is also available, consisting of two pumps installed in the same packaged. Units operating with compressed air are also available.